

UNITED STATES  
SECURITIES AND EXCHANGE COMMISSION  
Washington, D.C. 20549

FORM 8-K  
CURRENT REPORT  
PURSUANT TO SECTION 13 OR 15(d) OF THE  
SECURITIES EXCHANGE ACT OF 1934

Date of Report (Date of earliest event reported): **May 19, 2022**

**LORDSTOWN MOTORS CORP.**

(Exact name of registrant as specified in its charter)

**Delaware**  
(State or other jurisdiction  
of incorporation)

**001-38821**  
(Commission  
File Number)

**83-2533239**  
(IRS Employer  
Identification No.)

**2300 Hallock Young Road**  
**Lordstown, Ohio 44481**  
(Address of principal executive offices, including zip code)

Registrant's telephone number, including area code: **(234) 285-4001**

**N/A**  
(Former name or former address, if changed since last report)

Check the appropriate box below if the Form 8-K filing is intended to simultaneously satisfy the filing obligation of the registrant under any of the following provisions:

- Written communications pursuant to Rule 425 under the Securities Act (17 CFR 230.425)
- Soliciting material pursuant to Rule 14a-12 under the Exchange Act (17 CFR 240.14a-12)
- Pre-commencement communications pursuant to Rule 14d-2(b) under the Exchange Act (17 CFR 240.14d-2(b))
- Pre-commencement communications pursuant to Rule 13e-4(c) under the Exchange Act (17 CFR 240.13e-4(c))

Securities registered pursuant to Section 12(b) of the Act:

<u>Title of each class</u>	<u>Trading Symbol(s)</u>	<u>Name of each exchange on which registered</u>
Class A common stock, par value \$0.0001 per share	RIDE	The Nasdaq Stock Market LLC

Indicate by check mark whether the registrant is an emerging growth company as defined in Rule 405 of the Securities Act of 1933 (§230.405 of this chapter) or Rule 12b-2 of the Securities Exchange Act of 1934 (§240.12b-2 of this chapter).

Emerging growth company

If an emerging growth company, indicate by check mark if the registrant has elected not to use the extended transition period for complying with any new or revised financial accounting standards provided pursuant to Section 13(a) of the Exchange Act.

**Item 7.01 Regulation FD**

On May 19, 2022 at 12:00 noon Eastern Time, Lordstown Motors Corp. (the "Company") will hold its Annual Meeting of Stockholders (the "Annual Meeting"). A copy of the presentation to be provided by the Company at the Annual Meeting is attached as Exhibit 99.1.

The information in this Current Report on Form 8-K is being furnished pursuant to Item 7.01 Regulation FD. In accordance with General Instruction B.2 of Form 8-K, the information in this report shall not be deemed "filed" for the purposes of Section 18 of the Securities Exchange Act of 1934, as amended (the "Exchange Act"), or otherwise subject to the liabilities of that section, nor shall it be deemed incorporated by reference in any filing under the Securities Act of 1933, as amended, or the Exchange Act, except as expressly stated by specific reference in such filing.

**Item 9.01 Financial Statements and Exhibits.**

(d) Exhibits.

Exhibit Number	Description
-------------------	-------------

<a href="#">99.1</a>	<a href="#">Lordstown Motors Corp. Annual Meeting of Stockholders Presentation dated May 19, 2022</a>
104	Cover Page Interactive Data File (formatted as inline XBRL)

**SIGNATURES**

Pursuant to the requirements of the Securities Exchange Act of 1934, the registrant has duly caused this report to be signed on its behalf by the undersigned hereunto duly authorized.

**LORDSTOWN MOTORS CORP.**

By:           /s/ Adam Kroll            
Name: Adam Kroll  
Title: Chief Financial Officer

Date: May 19, 2022

---



  
**LORDSTOWN**  
MOTORS

Annual Stockholders' Meet  
Welco

5/19/20





# Angela Strand

---

Non-Executive Chairwoman  
Lordstown Motors Corp.

00  
00  
00  
00  
02



00  
00  
00  
00  
03

# Melissa Leonard

---

Executive Vice President,  
General Counsel & Secretary  
Lordstown Motors Corp.



# Angela Strand

---

Non-Executive Chairwoman  
Lordstown Motors Corp.



# LORDSTOWN MOTORS

Annual Stockholders' Meeting  
The meeting has converted

5/19/20





# LORDSTOWN MOTORS

Annual Stockholders' Meeting  
The meeting is adjourned

5/19/20







**LORDSTOWN**  
MOTORS

Annual Stockholders' Meeting  
Perspectives Then & Now

5/19/20





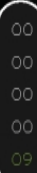

# Dan Ninivaggi

---

Chief Executive Officer  
Lordstown Motors Corp.

"THE ROAD AHEAD"

VIDEO  
OMITTED

---

**ENDURANCE™**  
is what got us here.



 LORDSTOWN





# Experienced Automotive Executive Team is in Place

00  
00  
00  
00  
12

CEO



**Dan Ninivaggi**

Former CEO of Icahn Enterprises LP; 20+ years in Sr. leadership positions in the automotive and transportation industries.

President

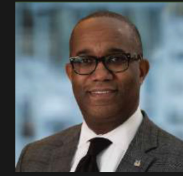

**Edward T. Hightower**

30 years of experience serving in product development, engineering, manufacturing, commercial, and sr. executive roles at Ford, BMW, and GM

CFO

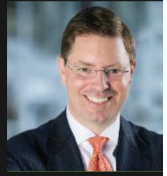

**Adam Kroll**

20+ years in corporate finance with Sr. roles in automotive investment banking (JP Morgan) and finance operations

CCO



**Jane Ritson-Parsons**

Senior executive with 30+ years demonstrated global leadership, new business and revenue generation and brand building success at Hasbro Inc.

Senior VP



**Shea Burns**

25-yrs. of automotive experience, including Vehicle Launch Leader at Ford and Sr. Director of Quality & Director of Engineering Operations at Meritor

Exec. VP



**Melissa Leonard**

Co-leader of the M&A team for Baker & Hostetler LLP where she served as outside counsel to the Company since 2019

# Strategic Pivot

Then

Now

High fixed cost structure

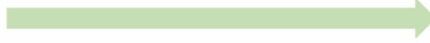

High variable cost structure

Sole management of supply base

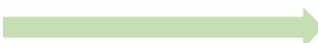

Leverage Foxconn's broad supply chain and logistics capabilities

Sole vehicle development responsibility

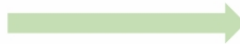

Joint development with Foxconn utilizing a common platform; \$100M commitment

Endurance™ platform

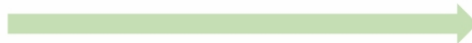

Broader Product Strategy  
Endurance™ plus MIH - with optionality

North American Focused

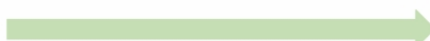

Global Potential with Foxconn

Manufacturing Centric

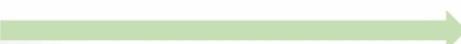

Engineering and product development centric

Traditional vertically integrated  
OEM without scale

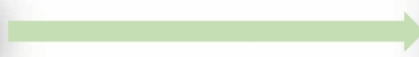

Flexible and less capital-intensive business model focused  
on partnerships to achieve scale benefits

Source: Lordstown Motors Corp.



## Solidified Long Term Relationship with Foxconn

---

- ❶ **Sold Lordstown facility for \$260 million**
  - ~400 experienced automotive personnel became Foxconn employees
  - Retained ~250 professionals with deep automotive experience, including in engineering, product development, quality and industrialization of
- ❷ **Executed contract manufacturing agreement**
  - Foxconn will manufacture the Endurance™ at the facility with no interruption in operation
- ❸ **Formed MIH EV Design LLC JV with \$100M investment to co-develop vehicles off MIH platform for LMC and potentially other OEMs**
  - Accelerates timeline, lowers the cost of development, and provides significant benefits



Source: Lordstown Motors Corp.



# Strategic Shift - Fixed to Variable Cost Business Mode

LMC has a unique business model - less capital intensive and mostly variable cost. Monetizing the plant and partnering with Foxconn enables LMC to achieve the benefits of scale without the complexities, risk and fixed costs of a vertically integrated global automaker

Lordstown Facility Costs	LORDSTOWN	
	1Q22	Pro Forma
Cost of manufacturing employees <sup>1</sup>	\$10M	\$0M
Direct/Indirect operating costs <sup>1</sup>	\$6.5M	\$1.2M
Freight <sup>1</sup>	\$5.5M	\$5.5M
<b>Total<sup>1</sup></b>	<b>\$22M</b>	<b>\$7.7M</b>

1) Estimates based on Q1 2022 results and provided for illustrative purposes  
 2) Purchasing transition expected to take place during the remainder of 2022

## Substantially Reduced Complexity & Operating Risk

- No maintenance, upkeep, utilities and other cost on 6.2M sq ft automotive plant built in 1966
- Eliminate excess capacity costs on 400K units/yr. plant capacity
- Not managing inventory or the entire production process
- Substantially reduce fixed payroll costs
- Transition of core purchasing function to achieve supply chain benefits<sup>2</sup>

Replaced with a fee per vehicle



# Joint Venture for Vehicle Development

- Signed MIH EV Design LLC Joint Venture (JV) agreement to develop and launch new electric vehicles utilizing Foxconn's Mobility-in-Harmony (MIH) open platform.
- JV includes \$100 million in initial funding with 55%/45% Foxconn/LMC ownership split
- Accelerates the benefits of scale as LMC can leverage its EV product development and engineering capabilities across a broader platform

## Foxconn's EV Pillars

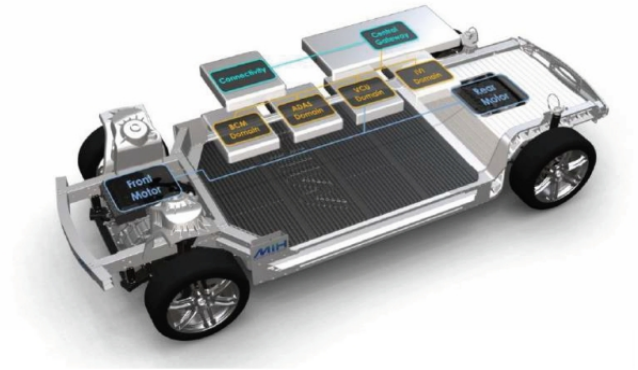
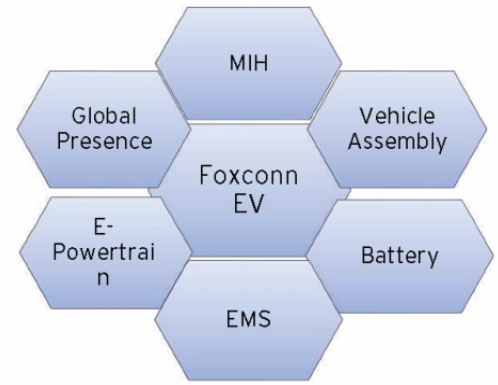

Source: Lordstown Motors Corp. & Foxconn



# Edward T. Hightower

---

President  
Lordstown Motors Corp.



# The Endurance™ BEV - Near Launch Ready

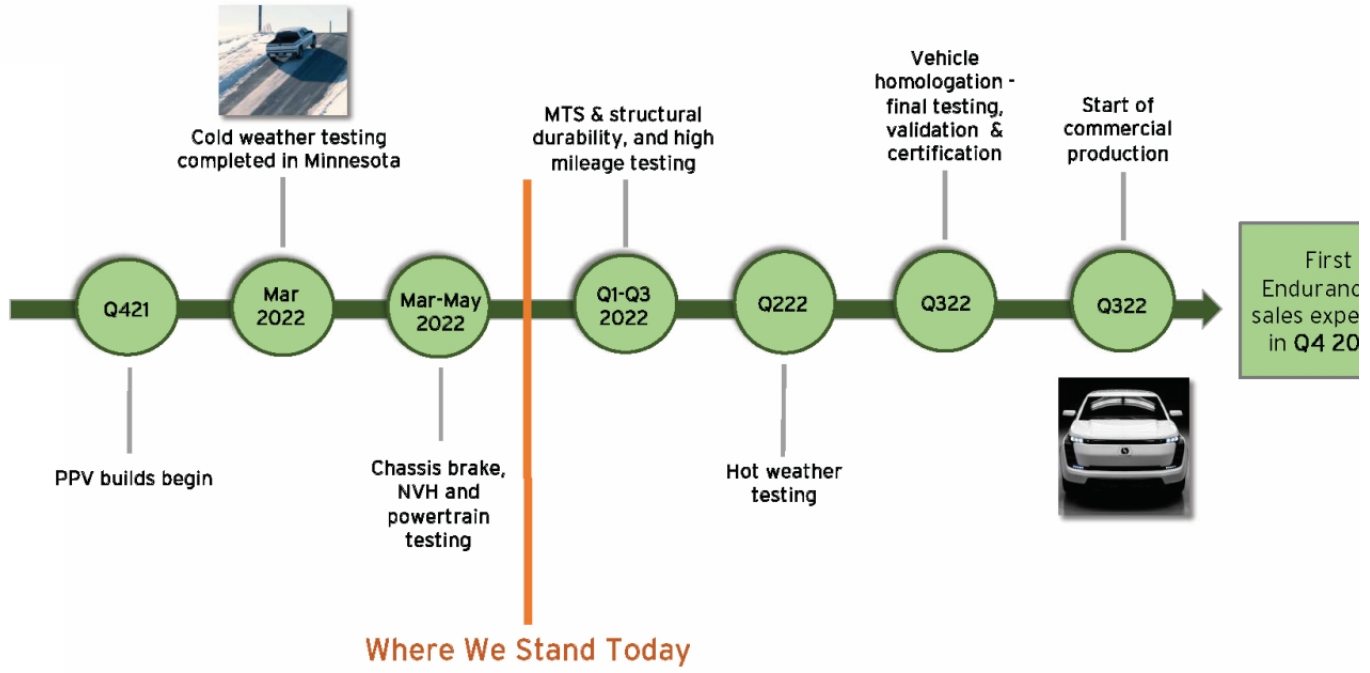



# Endurance™ PPV Testing & Validation

Our PPV testing and validation program continues



- 🔧 Engineering validation and test continues
- 🔧 Currently building Endurance PPVs for homologation and certification, including tests for the EPA, CARB, and FMVSS
- 🔧 Latest FMVSS frontal, side, and rear crash tests have been positive and consistent with CAI simulations. Prediction of 5-star crash safety performance remains

00  
00  
00  
00  
19

Source: Lordstown Motors Corp.



# Endurance™ Design Journey - A Great Purpose-Built Work Truck

The dedicated design and engineering team at Lordstown has invested tens of thousands of hours, bringing a full-sized BEV to market to serve the needs of fleet customers - at a lower total cost of ownership

1

## Durability

The Endurance's™ simple skateboard delivers enhanced reliability and durability

2

## Maneuverability/Stability

The Endurance's™ four Hub Motors provide a low center of gravity boosting maneuverability to handle any jobsite

3

## Performance

Quick acceleration response; all the energy goes directly into wheels for immediate movement

4

## Traction

Superior traction on snow and ice; instant torque at the corners offers "planted" feel



00  
00  
00  
00  
20

Source: Lordstown Motors Corp.



# In-Wheel Hub Motors Deliver Superior Performance

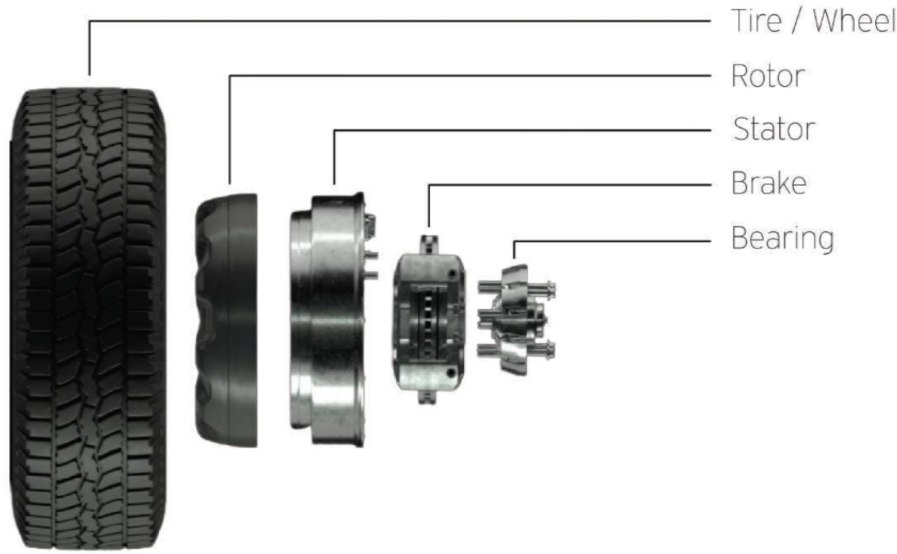

## Hub Motor Differentiators

- 🔌 Superior traction on snow/ice
- 🔌 Quick acceleration response
- 🔌 Maneuverability/stability - instant torque at corners (no lag response)
- 🔌 Small vehicle footprint/simplicity system - less maintenance and higher reliability
- 🔌 Lower center of gravity - "plant" feel
- 🔌 All the energy goes directly into wheels for immediate movement high motor efficiency

00  
00  
00  
00  
21

Source: Lordstown Motors Corp.



# Distinct Intellectual Property

↳ LMC has made substantial investments developing intellectual property to build the Endurance™ including:

- Hub motor and battery module and pack lines
- Vehicle architecture and central supervisory powertrain controller (VCU)
- Software and integrated controls

↳ LMC has significant expertise in (1) software development/integration; (2) body and chassis design; (3) test & validation activities

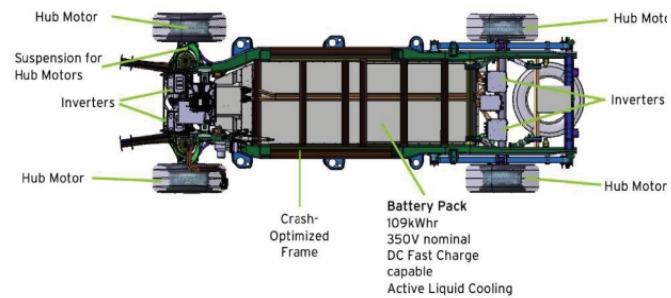

00  
00  
00  
00  
22

Source: Lordstown Motors Corp.



# \$100M Commitment to MIH EV Design LLC Joint Venture

**LORDSTOWN.**

Stronger Together

**FOXCONN®**

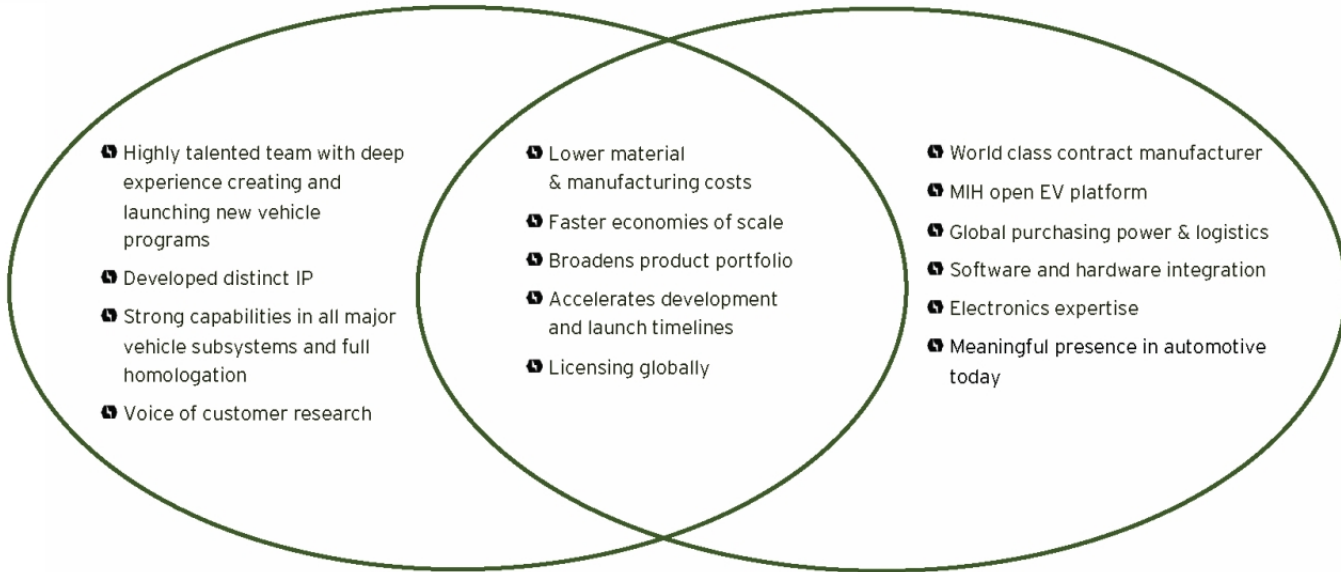

**Faster Path for EV Development at a Lower Cost with Foxconn**

Source: Lordstown Motors Corp.



# Why Lordstown Motors?

## Near Launch Ready

- Full-sized BEV pickup targeting the underserved commercial fleet market

## Unique Vehicle Attributes

- Purpose-built work truck, not a redesigned ICE, hub motors drive superior turning radius, traction and maneuverability

## Distinct IP

- Valuable IP covering vehicle architecture, software and integrated controls, battery systems & hub motors

## Strategic Shift

- From vertically integrated to highly flexible, less capital-intensive OEM focused on developing, engineering, and industrializing BEVs for LMC and potentially other OEMs

## Joint Vehicle Development

- Using Foxconn's scale and our design and engineering expertise to accelerate product development and launch timeline, lower costs and expand product breadth

## Strong Leadership

- Added significant talent to senior leadership with decades of automotive, engineering, vehicle launch and executive experience



OHIO



THANK YOU TO OUR TEAM!



MICHIGAN

CALIFORNIA



"RIDE WITH LORDSTOWN"

VIDEO  
OMITTED

---

INVESTOR RELATIONS  
ir@lordstownmotors.com

MEDIA INQUIRIES  
crobar@robarpr.com | 313.207.5960

**LORDSTOWN**

# Thank you!



#RIDEWITHLORDSTOWN



© 2022 LORDSTOWN MOTORS CORPORATION

May 19, 2022